

GL ROBERTO

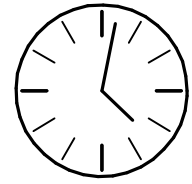

60 min

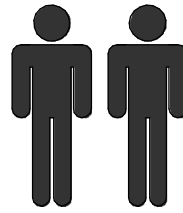

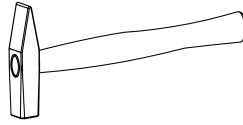
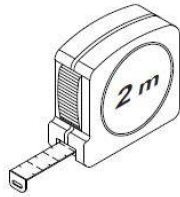
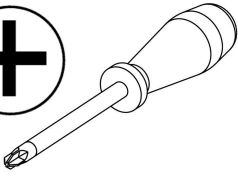
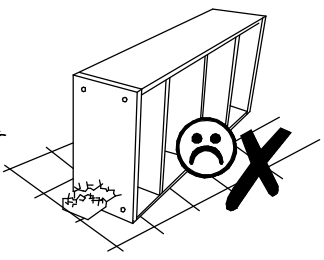
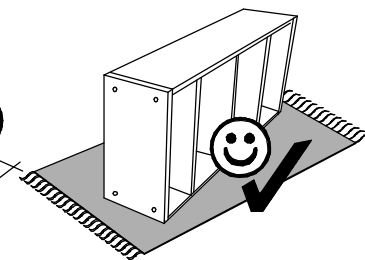
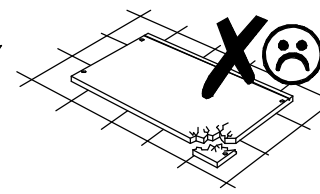
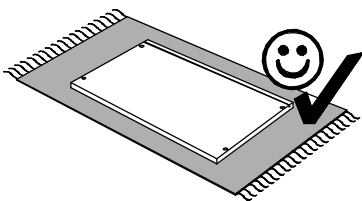
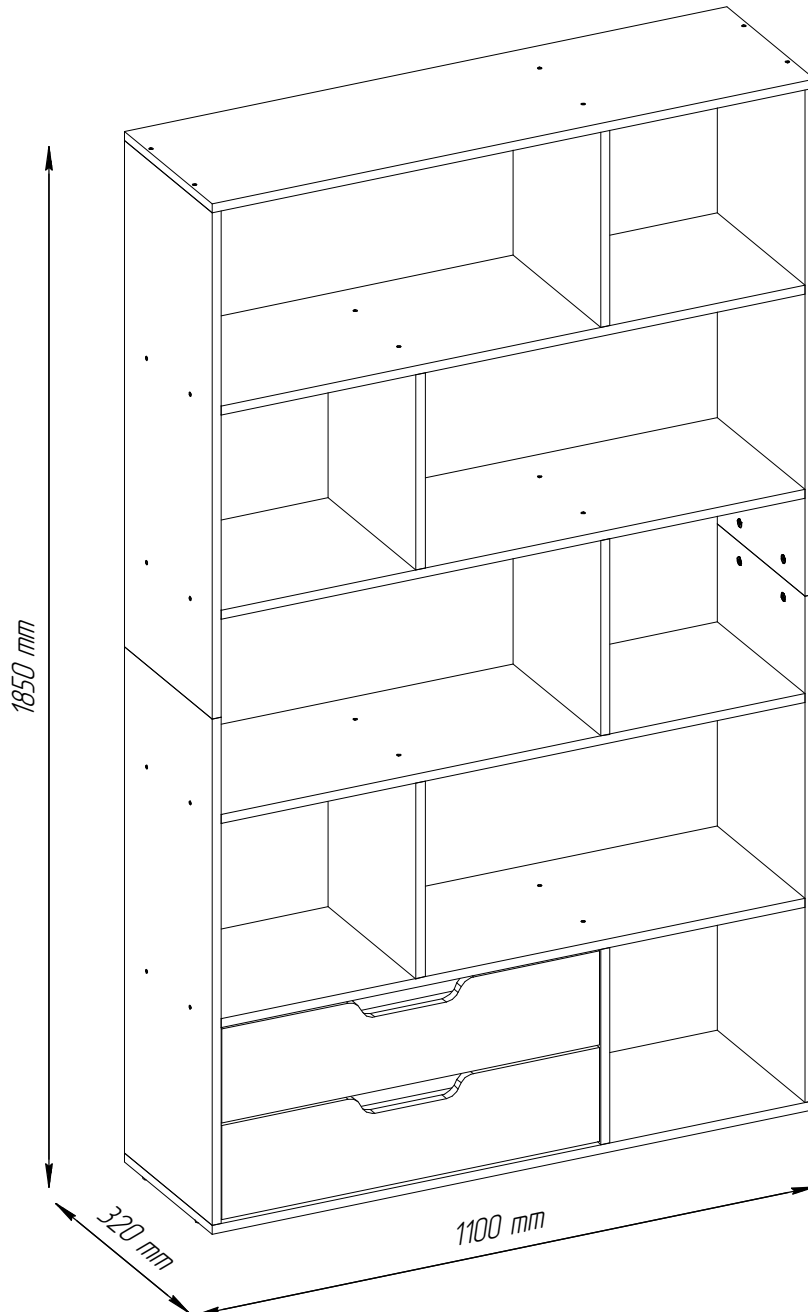
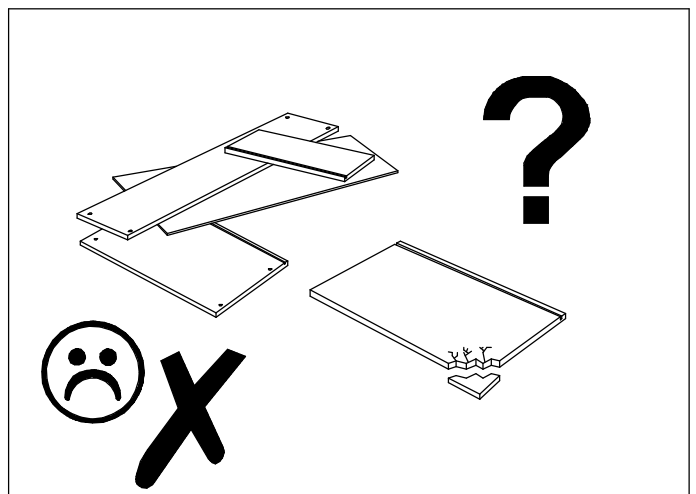
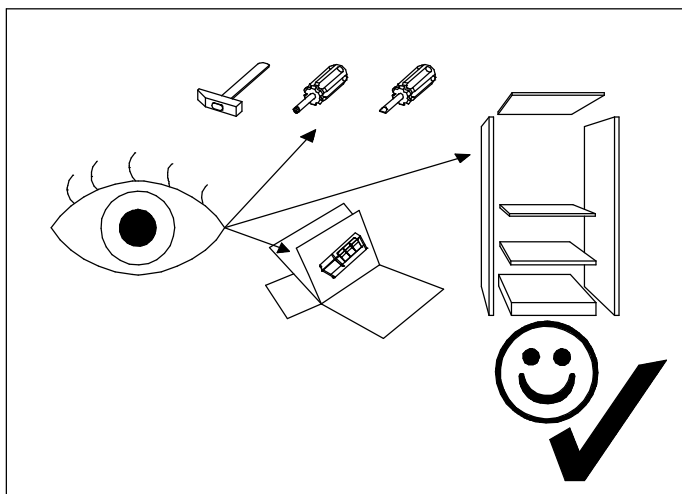
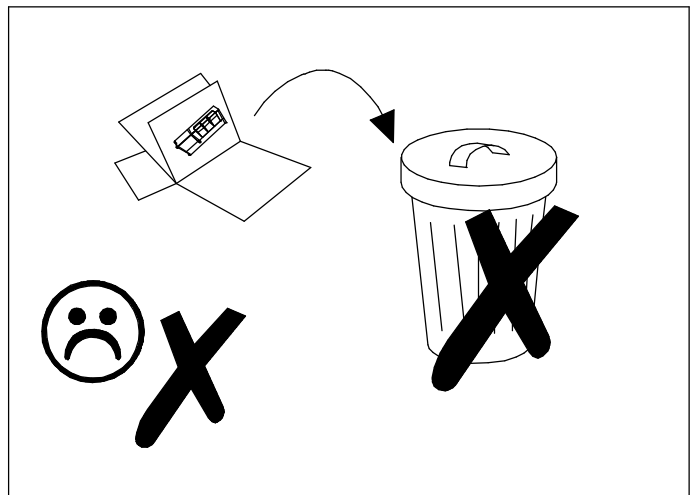
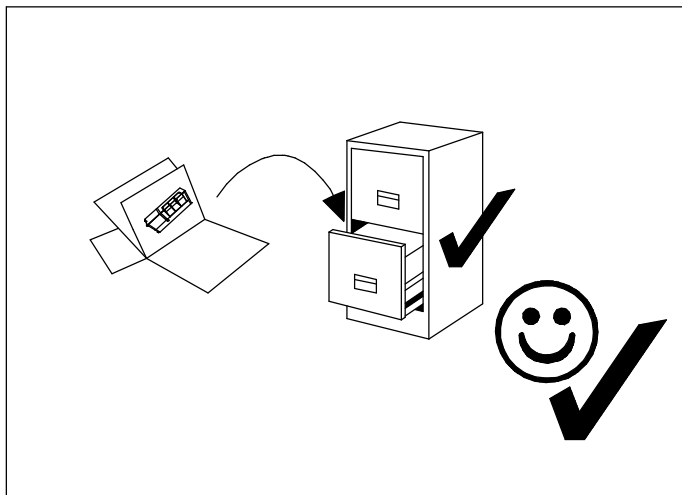
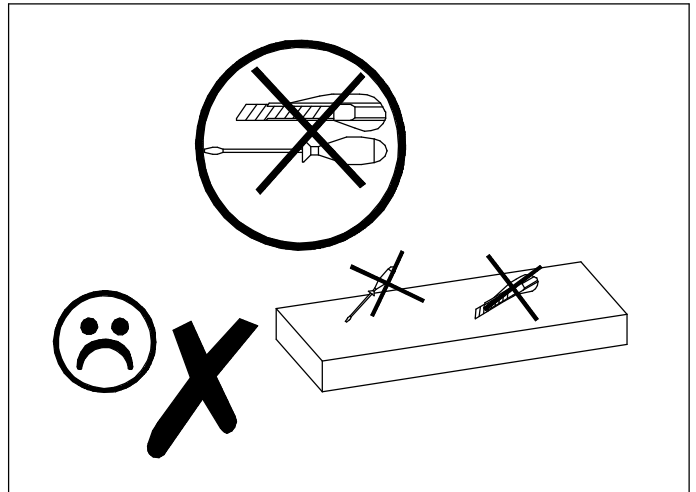
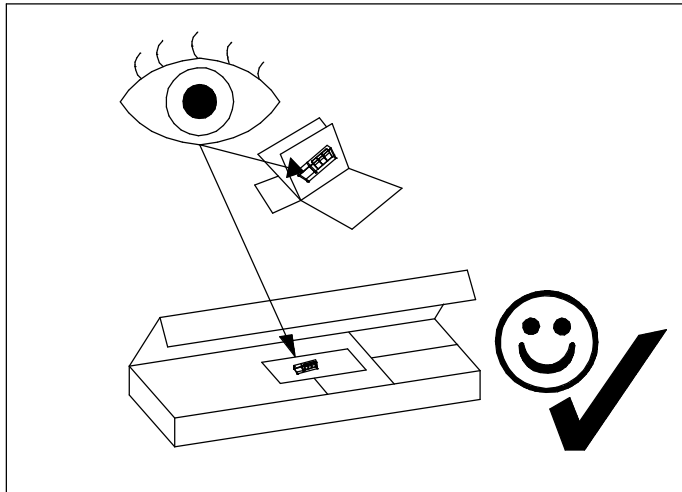

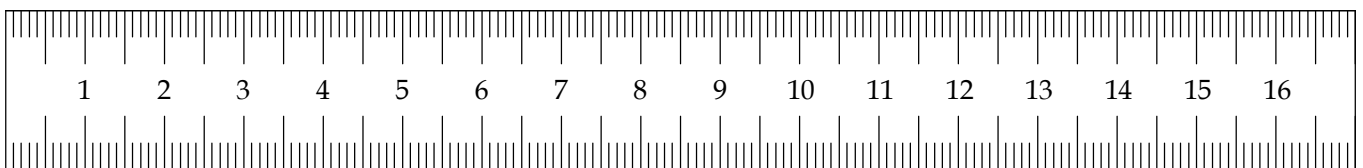
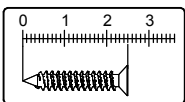
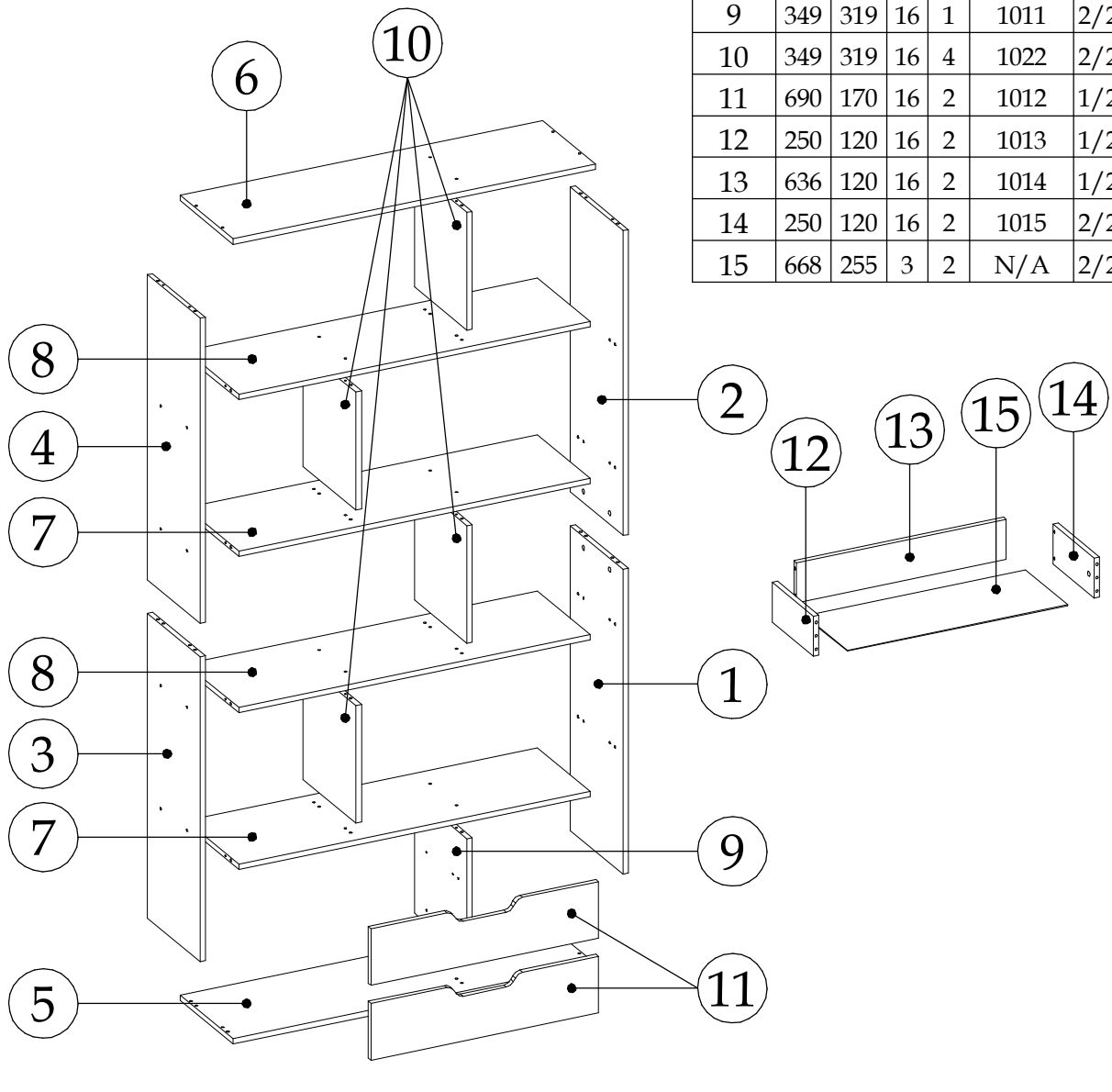
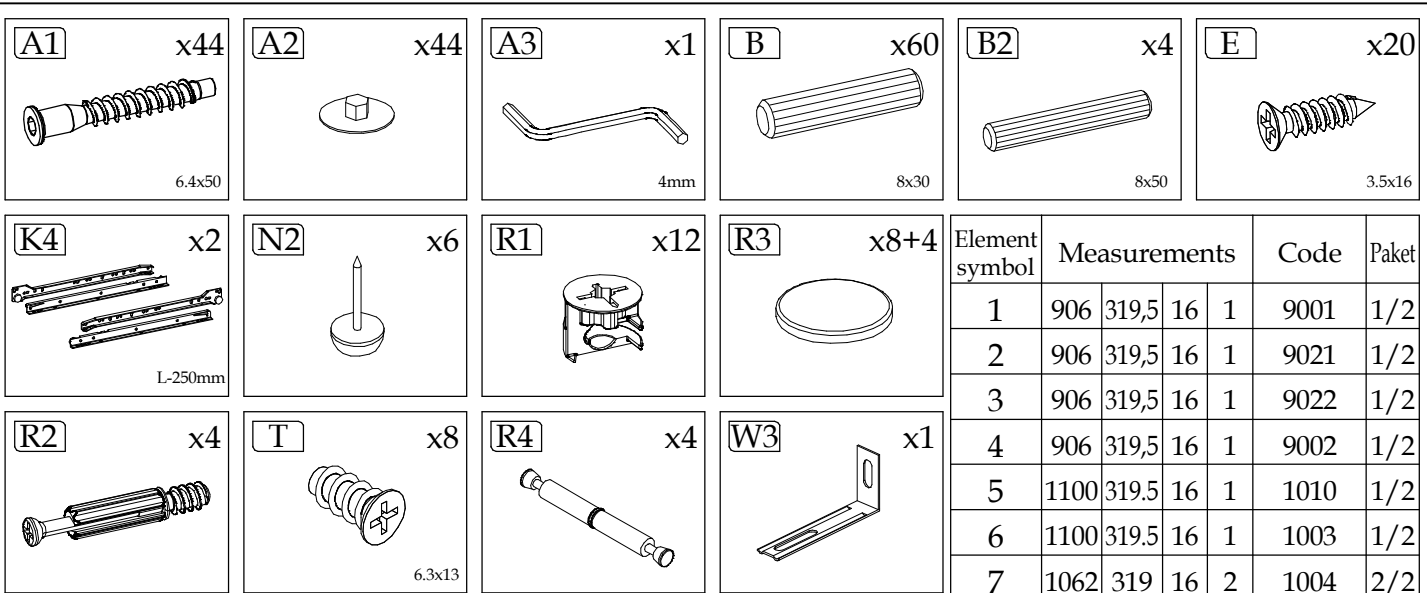

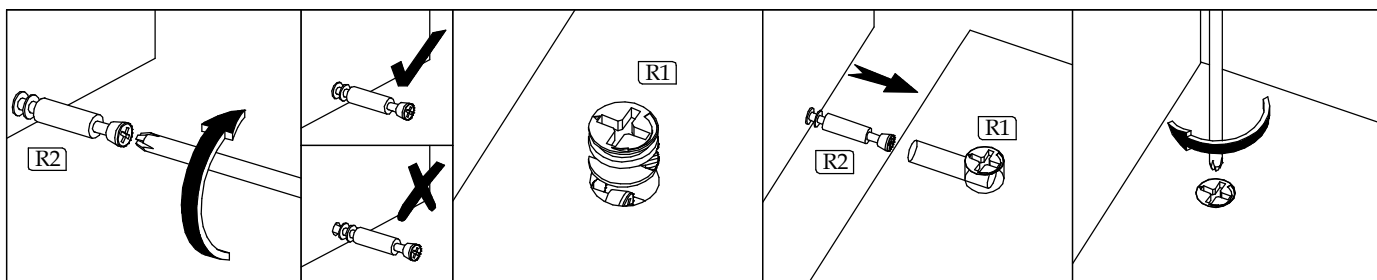

► 1

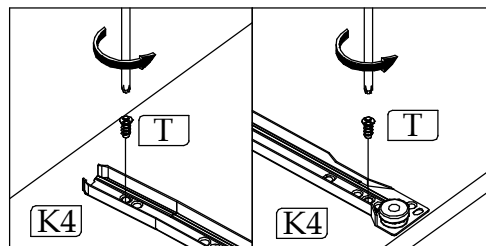
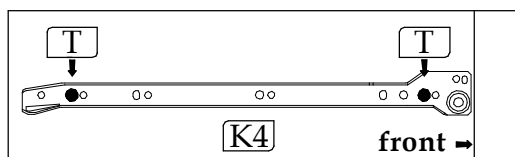
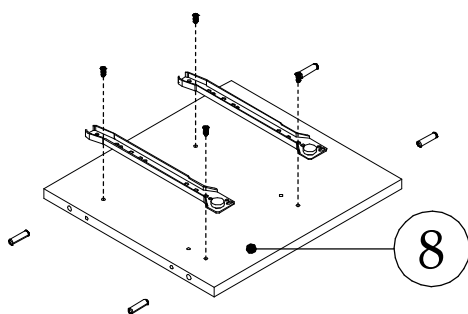
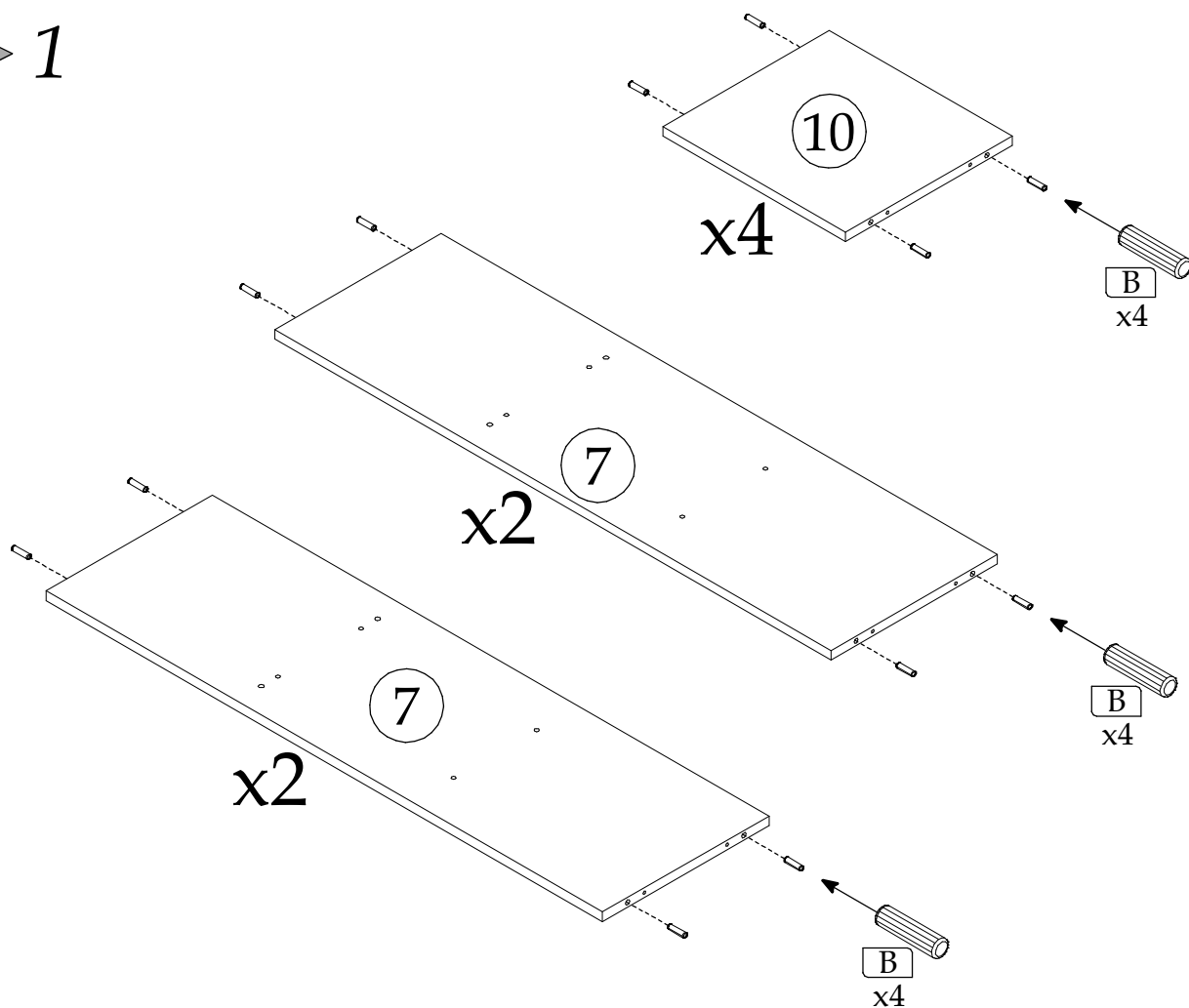

▶ 2

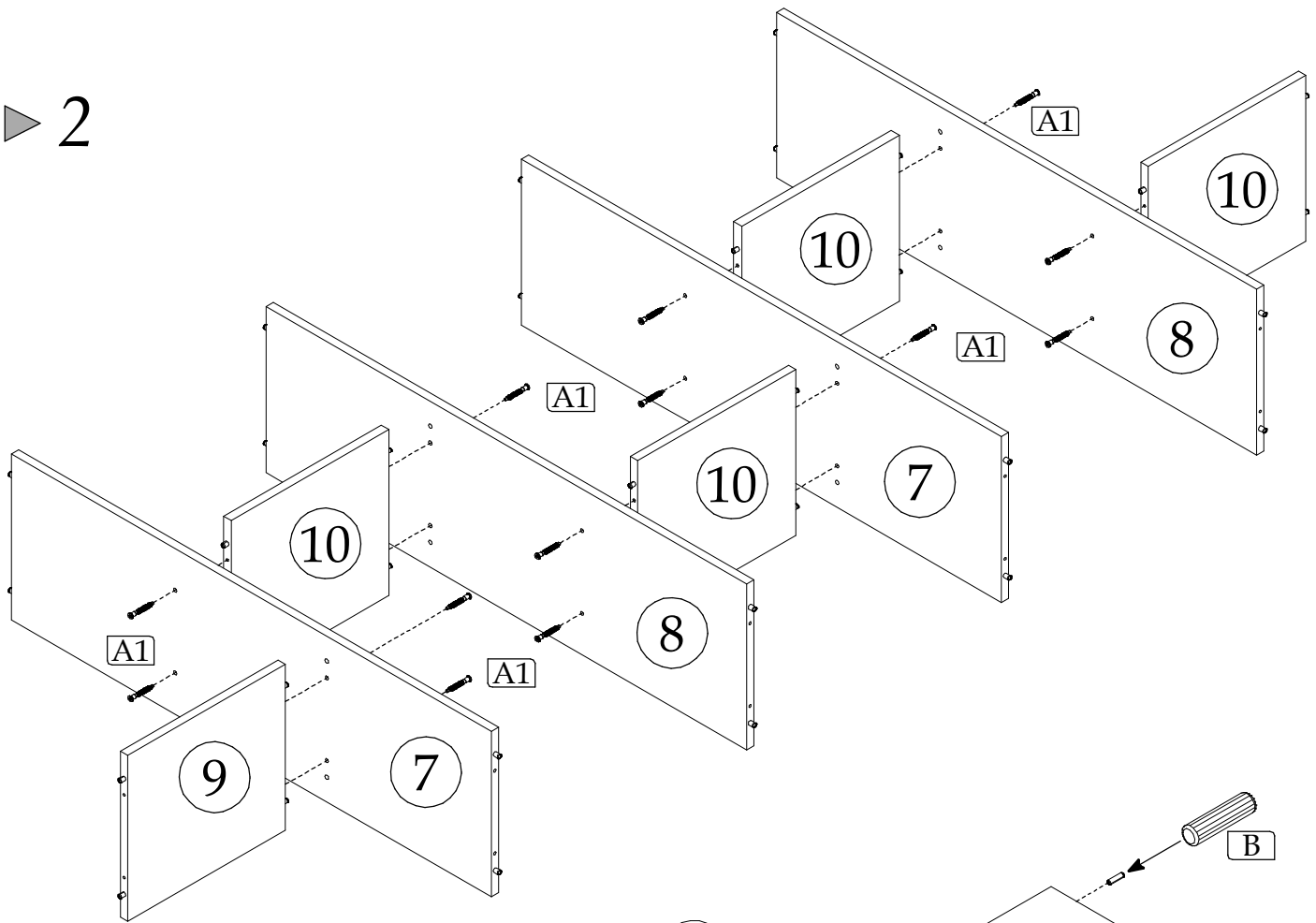

▶ 3

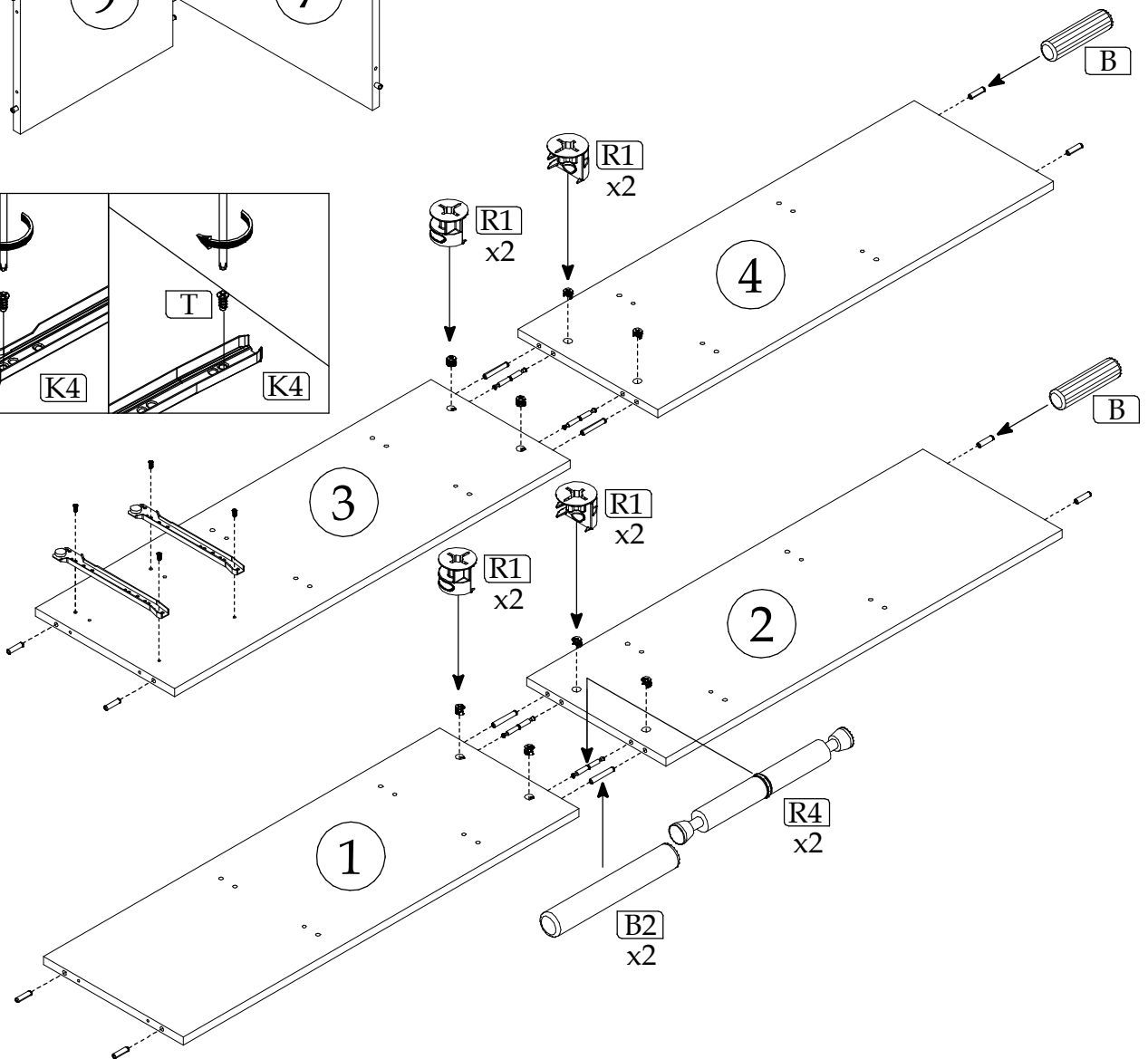
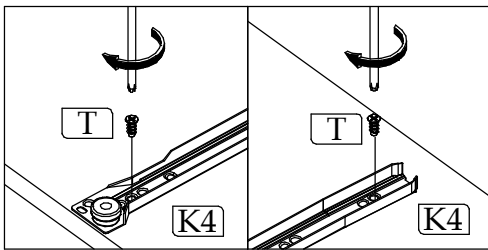

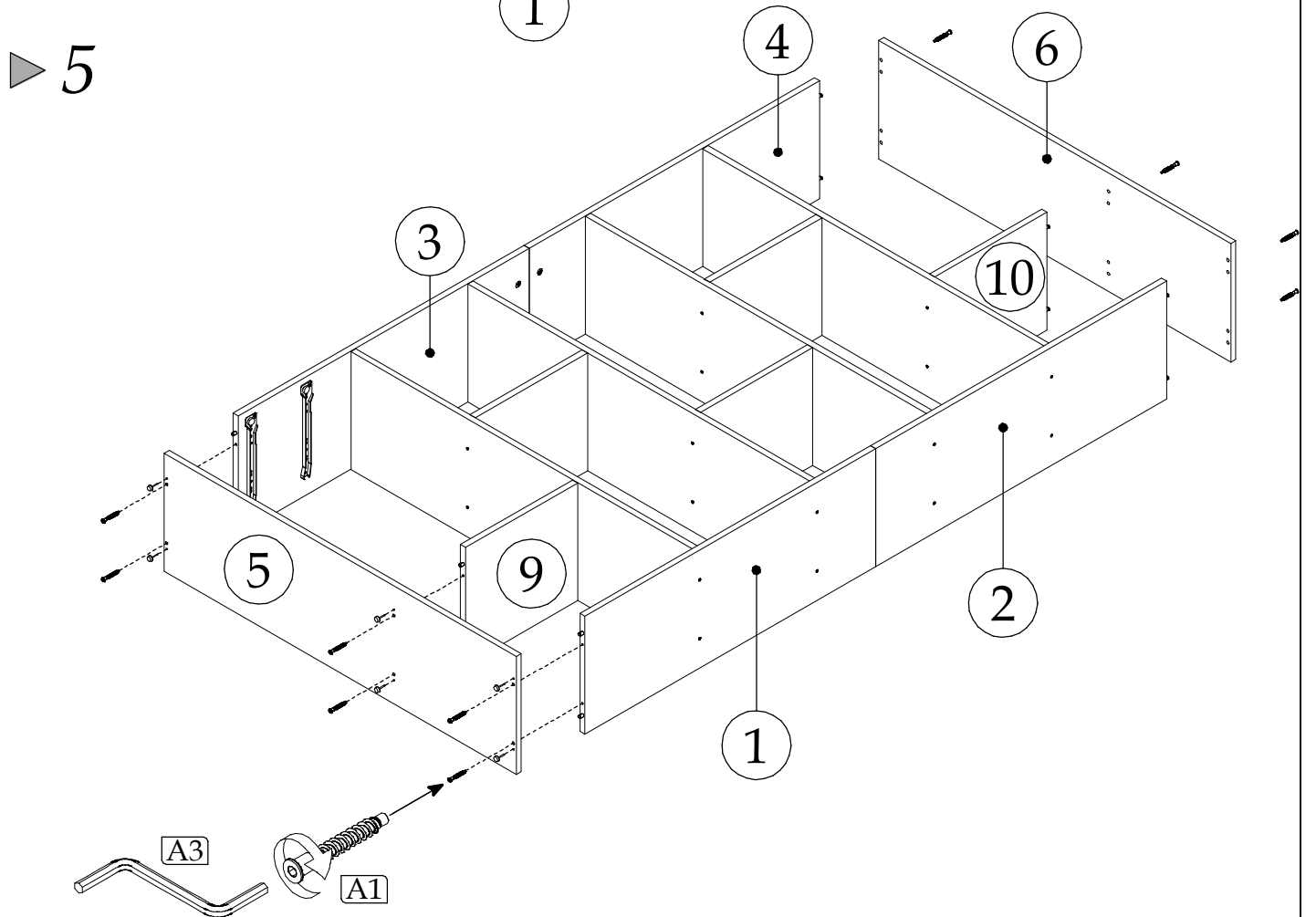
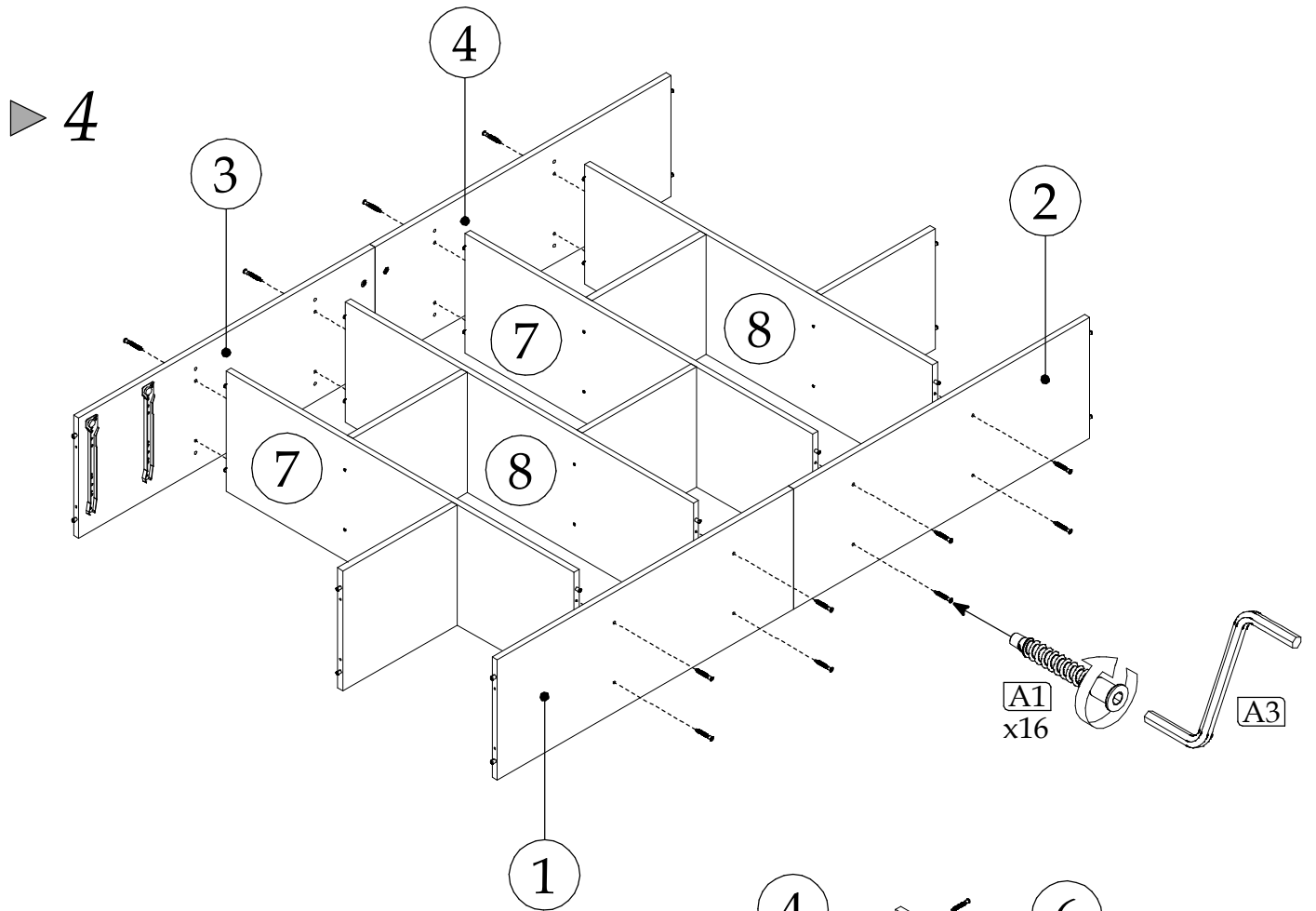

▶ 6

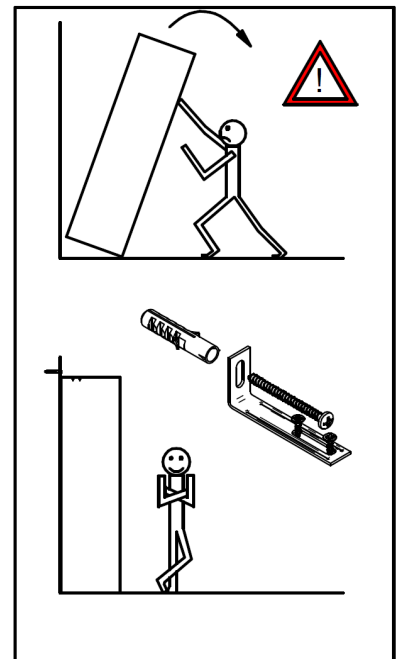
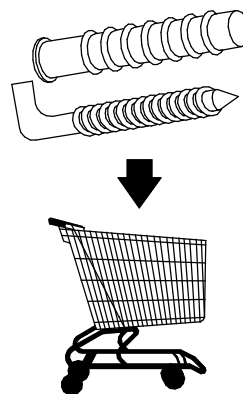
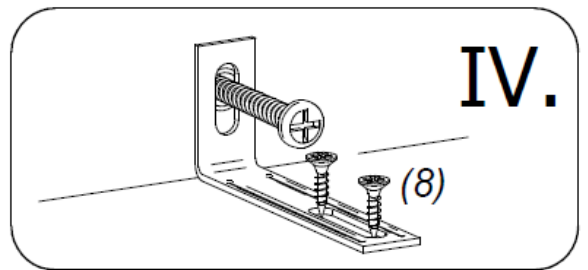
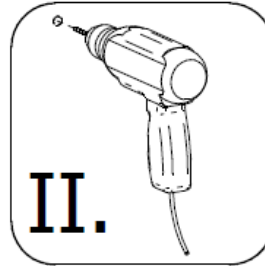
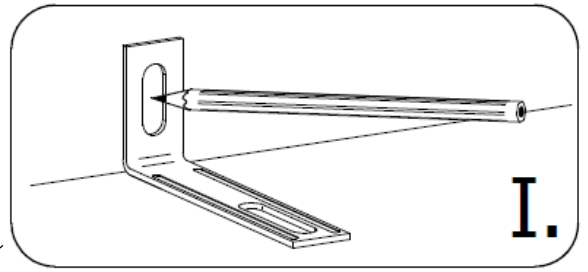
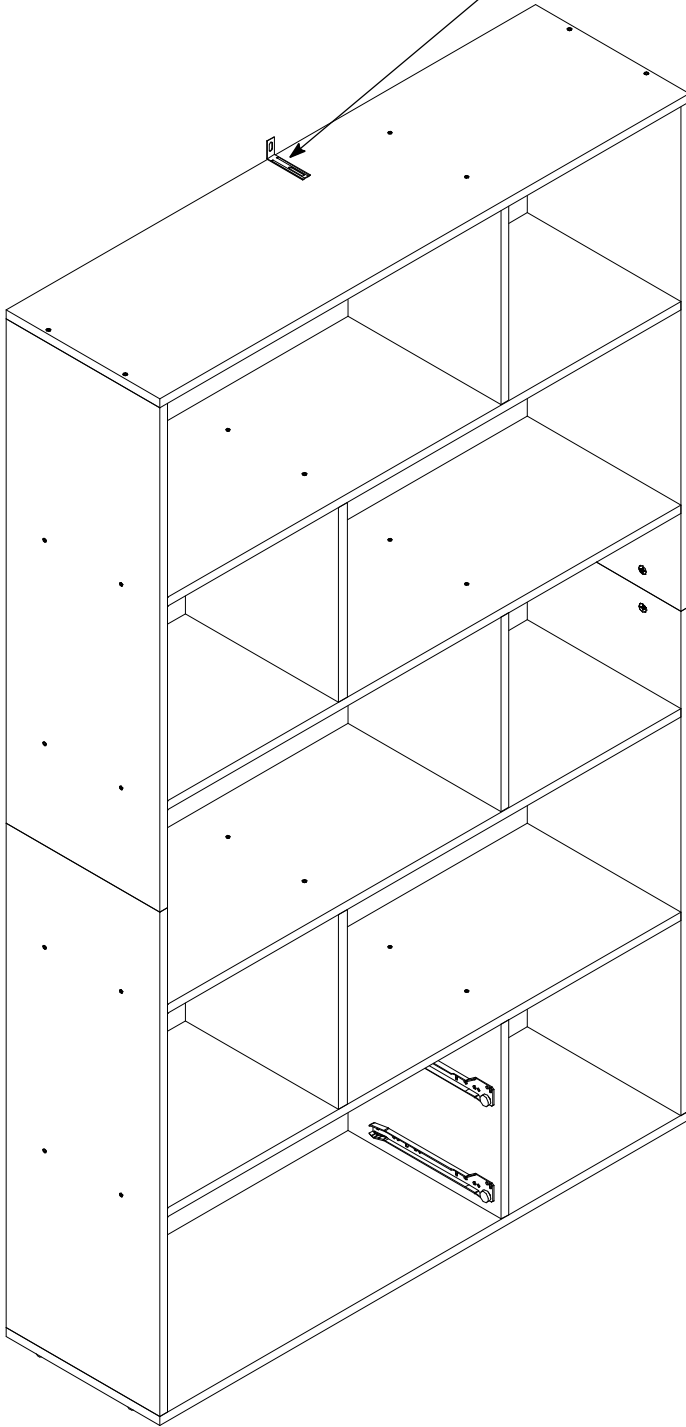

▶ 7

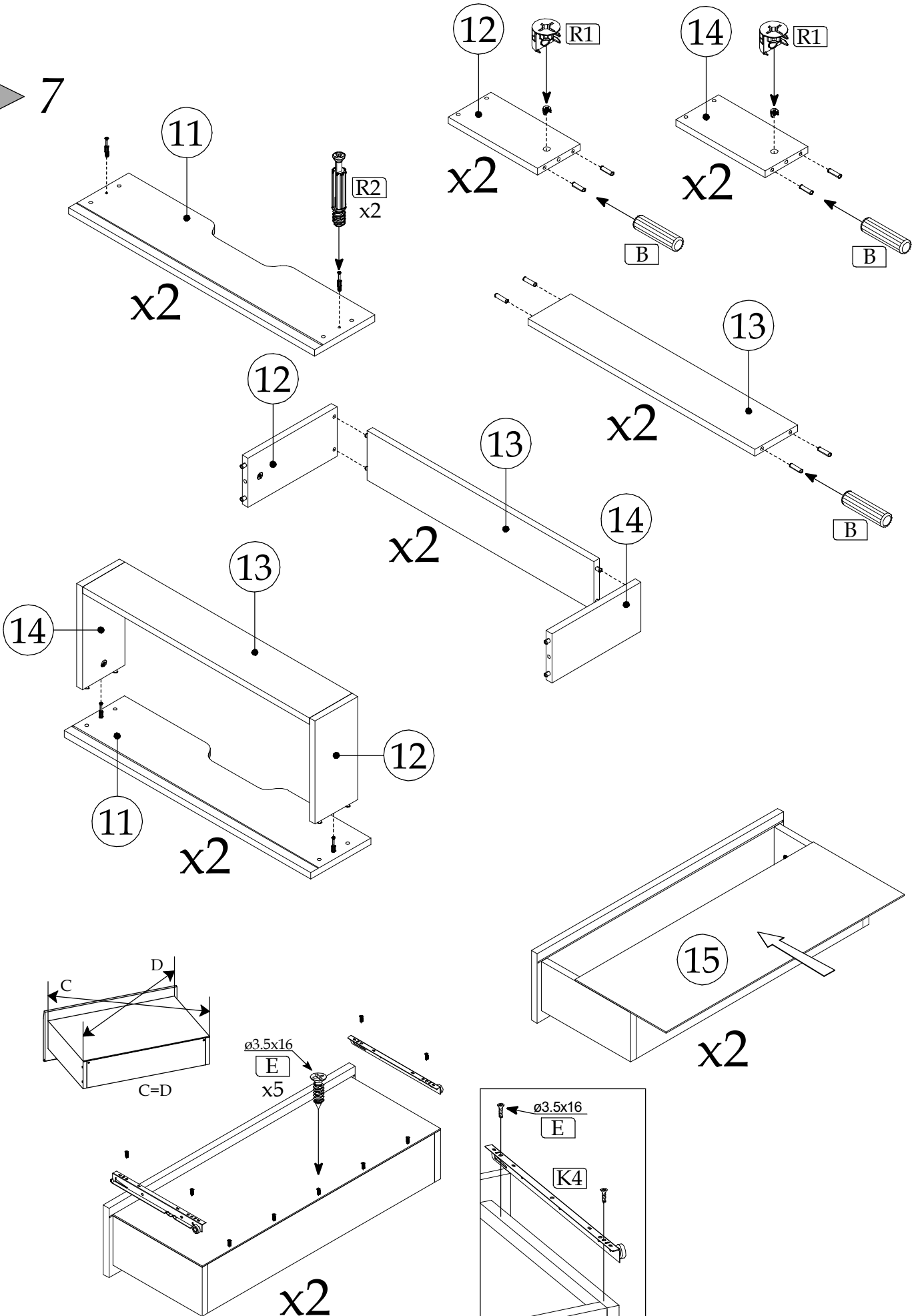

▶ 8

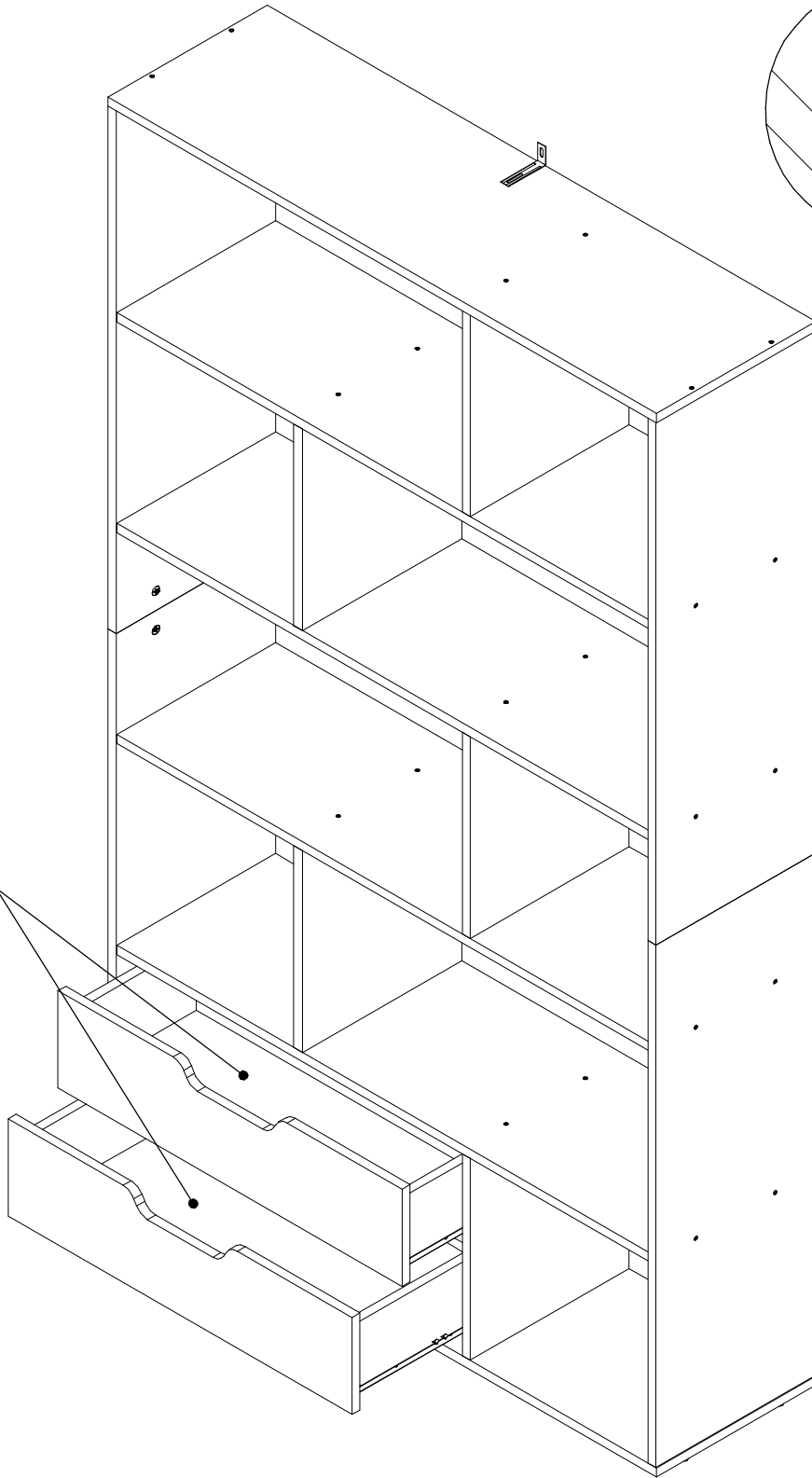

max
5 kg

